

# 3-Way Angle Milling Vise

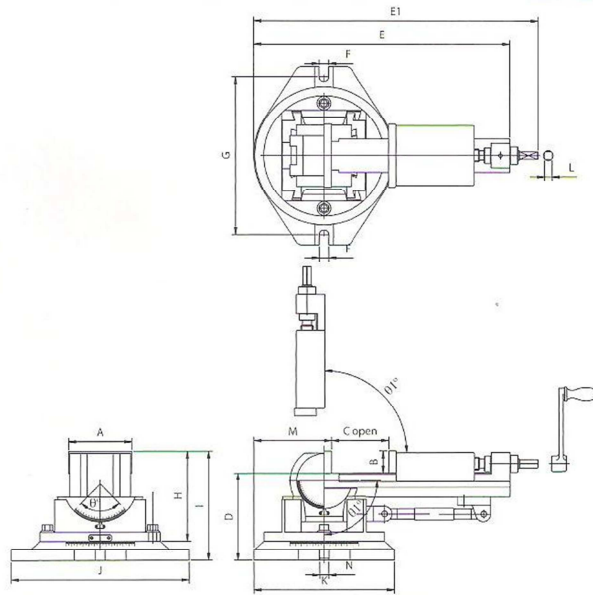
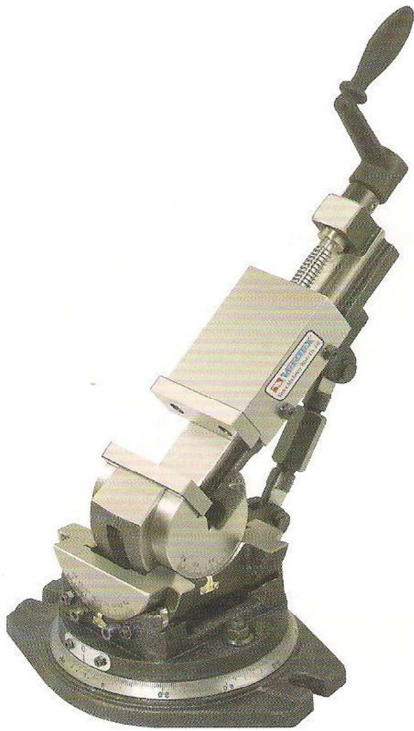

- Angles can be set in 3 dimensions. Swivels 360° around base. The vise can be elevated through 90° from the horizontal to vertical. And also can be tilted on its lower angle base up to 45° in both right and left.
- Tilting of any angle all keep the workpiece steady, smooth.
- Particularly the clamping part of screw is strengthened by a bush made of gunmetal.

## Specifications

Unit:mm

ORDER NO.	A	B	C OPEN	D	E	E1	F	G	H	I	J	K	L	M	N	θ	θ	Clamp Force (kgs)	G.W. (kgs)	Meas CFT	CODE NO.
VW-3	80	31	85	126	335	370	15	210	127	157	240	185	10	95	16	-45°~45°	-0°~90°	800	16.7	40x21x19	1002-080
VW-4	110	38	115	152	448	497	17	276	157	190	311	245	13	135	16	-45°~45°	-0°~90°	1000	32.7	56x27x23	1002-081
VW-5	135	40	150	170	530	580	17	310	173	210	358	271	13	140	16	-45°~45°	-0°~90°	1600	49.4	66x31x25	1002-082